



MODEL 95 ES



OPERATOR'S MANUAL

©2008
GUARDIAN ULV EQUIPMENT
PRODUCT OF ADAPCO, INC.

CAUTION

FAILURE TO FOLLOW SAFE OPERATING PRACTICES MAY RESULT IN INJURY

- Keep all shrouds and guards in place especially the drive belt shroud.
- Before performing any maintenance or service, stop the machine and disconnect the battery.
- Keep hands, feet and clothing away from power-driven parts.
- Read this manual completely as well as other manuals that come with this equipment.
- Use ear protection when in close vicinity of equipment when powered up.
- Do Not direct air blast from nozzle directly at any part of your body.
- Use appropriate PPE when loading tanks and performing calibrations.

**REMEMBER – YOUR ULV COLD FOG GENERATOR IS ONLY AS SAFE AS
THE OPERATOR!**

Hazard control and accident prevention are dependent upon the awareness, concern, prudence, and proper training of the personnel involved in the operation, transport, maintenance, and storage of the equipment.

**This manual covers the operating instructions, illustrations,
and parts lists for:**

Guardian 95 ES (standard)

Guardian 95 ES-EFO (extended fuel option)



TABLE OF CONTENTS

MODEL 95 ES

Contents

SPECIFICATIONS	5
GENERAL INFORMATION	7
INTRODUCTION	7
SERVICING THE ENGINE	7
DIRECTION REFERENCE	8
SAFETY INFORMATION	9
GENERAL SAFETY INFORMATION	9
SIGNAL WORDS	10
BEFORE OPERATION CONSIDERATIONS	11
OPERATION CONSIDERATIONS	13
MAINTENANCE AND STORAGE	14
FAMILIARIZATION	15
OPERATOR CONTROLS	15
AIR PRESSURE GAUGE	16
PRESSURE SWITCH	16
FORMULATION FILTER	16
FORMULATION TANK	16
INSECTICIDE PUMP	17
PULSE DAMPENER	17
FLUSH TANK AND VALVE	17
ATOMIZATION NOZZLE	18
INSTALLATION	19
COLD FOG GENERATOR (ULV SPRAYER) CONTENTS	19
FACTORY FLUID LEVELS	19
VEHICLE INSTALLATION	20
ENGINE STARTING	22



ENGINE SYMBOLS.....	23
KEY START	23
RECOIL START (PULL START)	24
REMOTE PENDANT START.....	24
MAINTENANCE.....	24
CHECKING ENGINE CRANKCASE OIL LEVEL	24
ENGINE AIR CLEANER	25
BLOWER LUBRICATION	25
BELT TENSION	27
LUBRICATION AND MAINTENANCE	28
CALIBRATION.....	29
FLOW CALIBRATION	29
DROPLET SPECTRUM CALIBRATION.....	31
WIRING DIAGRAM (SPRAYER).....	32
WIRING DIAGRAM (PENDANT)	33
FLOW DIAGRAM.....	34
TROUBLESHOOTING.....	35
ILLUSTRATED PARTS BREAKDOWN	36
GUARDIAN 95 ES DRIVE TRAIN	36
GUARDIAN 95 ES DRIVE TRAIN PARTS LIST.....	37
GUARDIAN 95 ES FLUID SECTION.....	38
GUARDIAN 95 ES FLUID SECTION PARTS LIST	39
GUARDIAN 95 ES NOZZLE AND FORMULATION TANK.....	40
GUARDIAN 95 ES EFO (EXTENDED FUEL OPTION)	41
NOTES	42
GUARDIAN ULV LIMITED WARRANTY	43

SPECIFICATIONS

Guardian 95 ES

Engine

Make	Kawasaki
Model	FE290-S21
Horse Power	9.5
Engine Type	Air cooled, 4-stroke, OHV, Single cylinder
Bore & Stroke	78 x 60 mm (3.07 x 2.36 in.)
Displacement	286 mL (17.5 cu. In)
Ignition System	Solid-state
Direction of Rotation	Counterclockwise facing the PTO shaft
Starting System	Recoil and Electric start
Charging System	13 A
Dry Weight	30.4 (67 lbs)
Fuel	Unleaded gasoline

Blower

Make	Gardner Denver
Model	3MP-LHC-0169
Dia. Outlet/Inlet	2" - S
Max Performance	3600 RPM
	9 PSIG
	169 CFM
	9.2 BHP
Configuration	Horizontal mount
	Left hand drive facing the PTO shaft
Weight	79 lbs.
Shaft Diameter	.75 (3/4")
Paint	Black

Drive Couple

Method	Belt, triple V
--------	----------------

Nozzle

Model	"VAAT" (Vectored Air Atomization Technology)
Size	2"
Material	Aluminum 6061-T6
Chem. Feed	Rear center, 1/4" OD tube, 1/4" NPT
No. of Pieces	3, nozzle body, nozzle hood, pre-feed input
Mounting	3.5" OD flange, 3" 4-hole bolt pattern
	Equally spaced, 1/4" SS fasteners
Nozzle Rotation	360° horizontally, 180° vertically

Capacity

Fuel	1.5 Gallon standard, 8.3 Gallon optional
Formulation	15 Gallon (56.7 liters) Lockable formulation tank cap
Flush	1.5 quart (1.42 liter)

Chemical Pump

Make	FMI for fixed or variable flow
Model	QB
Type	Positive displacement Piston
Piston	3/8" ceramic
or	
Make	Micro Pump for Mon4 variable flow only
Model	MFC (Modular Flow Control)
Type	Gear
Gears	PEEK

Flush Valve

Configuration	3-way diverter
Power	12V dc
Consumption	7 watts

Gauges

Fuel	Analog gauge, tank float
Pressure	0-15 PSI, glycerin filled, panel mounted
Throttle & Choke Control	
Throttle	manual
Choke	manual

Finish

Type	Epoxy Powder Coat chassis
------	---------------------------

Dimensions

Length	39"
Width	38
Height	29.8" horizontal, 41" nozzle pointed vertical
Weight	385 lbs. (dry)

GENERAL INFORMATION

INTRODUCTION

Your ULV cold fog generator, known from this point on in this manual as “ULV Sprayer”, was built to the highest standards in the industry. However, the prolonged life and maximum efficiency of your sprayer equipment depends on you following the operating, maintenance and adjustment instructions in this manual.

If additional information or service is needed, contact ADAPCO or if applicable, your authorized ADAPCO service representative.

We encourage you to contact ADAPCO for repairs. As the designer and manufacturer of this equipment, ADAPCO professionals are informed and trained on the latest methods to service this equipment and provide prompt and efficient service in the field or at the service shop and carry a full line of Guradian ULV service parts and accessories.

THE REPLACEMENT OF ANY PORTION OF THIS PRODUCT BY OTHER THAN THE MANUFACTURER’S AUTHORIZED REPLACEMENT PART MAY ADVERSELY AFFECT THE PERFORMANCE, DURABILITY OR SAFETY OF THIS PRODUCT. USE OF OTHER THAN ADAPCO/GUARDIAN ULV REPLACEMENT PARTS WILL VOID THE WARRANTY.

For some pictorial clarity, some illustrations and figures in this manual may show guards, or shrouds removed. Under no circumstances should your ULV sprayer be operated without these devices in place.

All information is based upon product information available at the time of approval for printing. ADAPCO, Inc. reserves the right to make changes at any time without notice and without incurring any obligation.

SERVICING THE ENGINE

The detailed servicing and repair of the engine is not covered in this manual; only routine maintenance and general service instructions are provided. For service of the engine during the limited warranty period, it is important to contact ADAPCO and if applicable, an authorized ADAPCO service representative or an authorized servicing agent of the engine manufacturer. **Any unauthorized work done on the engine during the warranty period may void your warranty.**



SAFETY INFORMATION

GENERAL SAFETY INFORMATION

Your ULV sprayer is only as safe as the operator. Carelessness or operator error may result in serious bodily injury or death. Hazard control and accident prevention are dependent upon the awareness, concern, prudence, and proper training of the personnel involved in the operation, transport, maintenance, and storage of the equipment. Make sure every operator is properly trained and thoroughly familiar with all of the controls before operating this spray equipment. The owner/user can prevent and is responsible for accidents or injuries occurring to themselves, other people or property.

**READ THIS OPERATOR'S MANUAL
BEFORE ATTEMPTING TO START
OR USE THIS SPRAYER.**

A replacement copy of this manual is available from ADAPCO, Inc. or if applicable, an authorized dealer or reseller of this equipment at:

ADAPCO, Inc.
Attn: Customer Service Dept.
550 Aero Lane
Sanford, FL 32771
Or call 1-800-367-0659

Additionally, a copy of this manual can be downloaded from the ADAPCO web site at www.MyADAPCO.com by using the model number.

SIGNAL WORDS

This general symbol means “Attention! Become Alert! Your Safety is Involved!” The symbol is used with the following signal words to attract your attention to safety messages found on the decals on the machine and throughout this manual.



The message that follows the symbol contains important information about safety. To avoid injury and possible death, carefully read the message! Be sure to understand the causes of possible injury or death.

Signal Word

The Signal word is a distinctive word found on the safety decals on the machine and throughout this manual that alerts the viewer to the existence and relative degree of the hazard.

The signal word “DANGER” denotes that an extremely hazardous situation exists on or near the machine that could result in high probability of death or irreparable injury if proper precautions are not taken.



The signal word “WARNING” denotes that a hazard exists on or near the machine that can result in injury or death if proper precautions are not taken.



The signal word “CAUTION” is a reminder of safety practices on or near the machine that could result in personal injury if proper precautions are not taken.



Your safety and the safety of others depend significantly upon your knowledge and understanding of all correct operating practices and procedures of this machine.

BEFORE OPERATION CONSIDERATIONS

1. Become familiar with the safe operation of the ULV sprayer and the operator controls.
2. **Never** allow children to play on or with the machine. **Never** allow children to ride in a vehicle sitting next to or on top of this machine.
3. Always wear appropriate clothing while operating, maintaining, servicing or calibrating this machine. The wearing of such items as safety glasses, aprons, gloves, and safety shoes is advisable and may be required by some local ordinances or insurance regulations.
4. Always wear hearing protection. Operating this machine for prolonged periods of time without hearing protection can cause permanent loss of hearing.



5. Keep the Spray machine and attachments in good operating condition. Keep all guards or shrouds in place. If a shield, safety device or decal is defective or damaged, repair or replace it before operating the machine.

6. Fill the fuel tank with clean, fresh, unleaded gasoline with a minimum octane rating of 87. To avoid personal injury or property damage, use extreme care in handling gasoline. Gasoline is extremely flammable and the vapors are explosive.

- a. Keep flammable objects (cigarettes, matches, etc.), open flames and sparks away from the fuel tank and fuel container.
- b. Use only an approved gasoline container.
- c. **DO NOT** add fuel to a running or hot engine. Allow the engine to cool for several minutes before adding fuel.



- d. Never fuel the machine indoors or in a small enclosed area without ventilation.
 - e. Never store the sprayer or fuel container where there is an open flame, spark or pilot light such as on a water heater or other appliance.
 - f. Never fill containers inside a vehicle or on a truck or trailer bed with a plastic bed liner. Always place the container on the ground away from your vehicle before filling.
 - g. Keep the nozzle in contact with the rim of fuel tank or container opening at all times until fueling is complete. We recommend not using a nozzle lock-open device.
 - h. If fuel is spilled on clothing, change clothing immediately.
 - i. Replace gas cap and tighten securely.
7. Fill chemical tank to the indicated full level not to exceed 15 U.S. gallons.
 - a. Keep fill nozzle securely in the opening at all time while chemical is being transferred. We recommend not using a nozzle lock-open device.
 - b. Wear appropriate personal protective equipment while filling chemical tank as required by the specific label of the product being filled.
 - c. Ensure chemical tank filling is accomplished in a well ventilated area.
 - d. Affix an approved label to the chemical tank indicating its contents after filling.
 - e. Thoroughly clean hands after handling chemical filling equipment.

OPERATION CONSIDERATIONS

1. **DO NOT** permit untrained personnel to operate the machine.
2. Before operating this sprayer, familiarize yourself with all sprayer functions and engine controls. Knowing the location, function and operation of these controls is important for safe and efficient operation.
3. **DO NOT** touch the engine muffler or any part of the exhaust system while running; wait several minutes for the engine and exhaust to cool and check for heat before doing so.

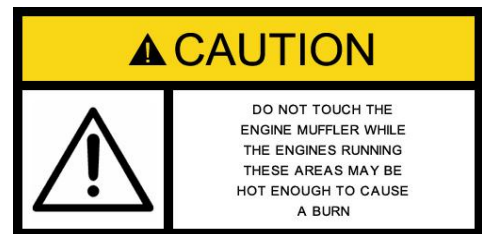

4. Blower housing and tubing to the nozzle, including swivel elbows and nozzle become very hot during prolonged operation. **DO NOT** touch any of these areas while running; wait several minutes allowing these components to cool before touching.
5. **DO NOT** operate the engine without the blower intake air filter housing being installed. Debris, cleaning rags or clothing can be sucked into the blower causing potential damage to the blower or injury to operators.
6. **DO NOT** direct the air blast from the nozzle at any portion of the body and especially the face. High volume air can penetrate the skin and cause serious injury even death. Always point the nozzle in an upward- attitude when sprayer is running and above head level for those on the ground. It is not recommended for anyone to be standing above the level of the nozzle when running even if the machine is mounted securely on a vehicle.





7. **NEVER** walk directly into the air/chemical blast from the nozzle when insecticide or any other formula is being atomized.
8. **DO NOT** direct the air/chemical discharge towards bystanders or allow anyone near the machine while in operation.

9. **DO NOT** run the engine inside a building or a confined area without proper ventilation. Exhaust fumes are hazardous and contain carbon monoxide which can cause brain injury and death.



10. **DO NOT** operate the machine under the influence of alcohol or drugs.
11. Use care when loading or unloading the machine onto a truck or trailer.
12. Do not change the engine governor settings or over-speed the engine. See the engine operator's manual for information on engine settings.
13. **NEVER** leave the machine running unattended.

MAINTENANCE AND STORAGE

1. Allow only trained personnel to service the ULV spray machine.
2. Park the vehicle or place the machine on level ground for fluid level verification.
3. Never make adjustments to the machine with the engine running unless specifically instructed to do so. If the engine is running, keep hands feet and clothing away from moving parts.
4. Stop engine and remove key or disconnect spark plug wire(s) to prevent accidental starting of the engine when servicing or adjusting the machine. Wait for all movement to stop before adjusting, cleaning or repairing.
5. Keep all nuts, bolts and screws tight to ensure the machine is in safe working condition.
6. The engine must be shut off before checking the oil or adding oil to the crankcase.
7. Let the engine cool before storing.
8. **DO NOT** store the machine near an open flame.
9. Shut off fuel while storing or transporting. 
10. To shut off engine for prolonged periods of time or seasonal storage, shut off the fuel valve and let the engine run out of fuel before turning the key to the off position. 

FAMILIARIZATION

OPERATOR CONTROLS

The below illustration shows the standard operator control pendant and its functions:

1. Power switch when asserted (turned on) applies power to the control pendant as well as provides operating voltage to allow fuel flow to the engine.

2. RED LED (Light Emitting Diode) when illuminated implies the power switch has been turned on and ready to receive commands.

3. Engine on-off-start switch is a 3 position switch that controls the status of the sprayer's engine. When in the OFF position, a control voltage is sent to the relay beside the engine. When this relay is energized, the engines ignition system is shorted to Ground. When in the ON position, the engine is ready to run and the ignition is ready. The START position is a spring loaded momentary switch that engages the engines starter motor and will continue to engage the starter until the engine is started or the switch is released.

4. Choke switch- is inoperative on this model 95 ES.

4. Choke switch- is inoperative on this model 95 ES.

5. Flush switch when in the ON position sends a control voltage to the 3-way electric solenoid valve which is connected to both the flush tank and the main formulation tank. Selecting the flush ON position selects the contents of the flush tank to be pumped through the insecticide pump when the spray switch is turned on.

6. Yellow LED when illuminated implies the flush tank has been selected.

7. Spray on/off switch turns the insecticide pump on and off when this switch is asserted. If the sprayer is running (engine on) and the spray switch is asserted, the pump will begin to run at a calibrated rate. If the engine is not running and the toggle switch on the pump electronic enclosure is in the down position, the pump will not run when the spray switch is turned on.

8. Green LED when illuminated implies the pump switch is in the ON position and if the sprayer is running, the pump will run and insecticide or flush solution will flow through the sprayer to be atomized.

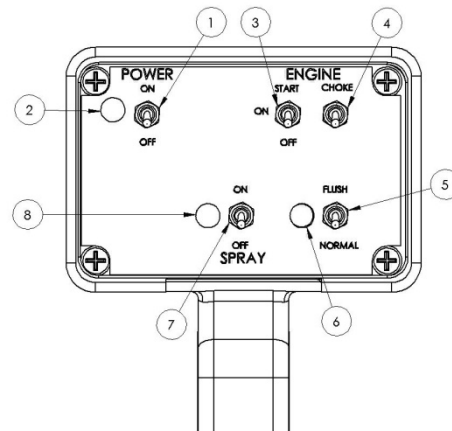

AIR PRESSURE GAUGE

The air pressure gauge is a glycerin filled type with a pressure range from 0-15 psig. When the engine is running and throttle adjusted to the desired engine RPM, atomization nozzle back pressure is most often the overriding factor in assuring correct atomization of a given flow rate or range of flow rate. Back pressure is measured from a fitting on the baffle box through a short flexible hose to the gauge.

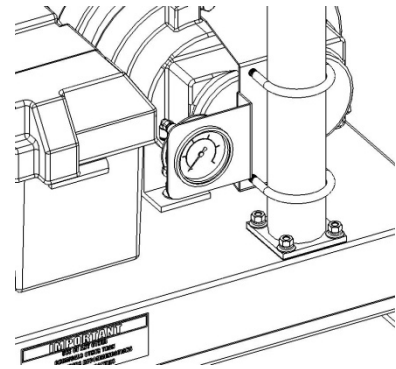

PRESSURE SWITCH

A pressure switch is located on the side wall of the “Wet” section of this ULV sprayer. Attached to it is a section of flexible hose back to a fitting located on the baffle box. The purpose of this pressure switch is to ensure the insecticide pump cannot be inadvertently turned on without sufficient air pressure. If this was to occur, the pressure switch does not allow the circuit to “make” thus the insecticide pump will not run. The pressure switch can be overridden by asserting the toggle switch on the back end of the pump’s electronic enclosure (toggle up) allowing the pump to run regardless if back pressure is present or not.

FORMULATION FILTER

Product to be atomized through this ULV sprayer must be filtered before it is drawn through the insecticide pump to ensure uniform fluid consistencies and prevent contamination and potential particulate damage. The glass filled polypropylene filter assembly consists of 4 pieces; top, bottom, gasket, and stainless steel 80 mesh screen element. Check this filter often or no less than once per hundred hours of operation. If you find that the filter is collecting more and more contaminants, consider cleaning and flushing the formulation tank more often.

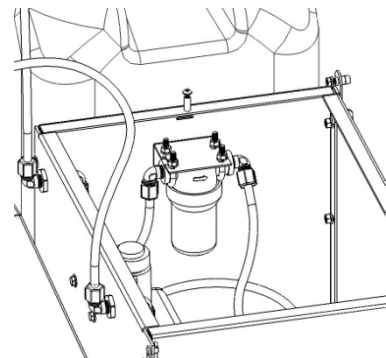

FORMULATION TANK

15 U.S. gallons (56.7 liters) is the capacity of the formulation tank installed on this ULV sprayer. The black high density polyethylene (HDPE) tank is suitable for all known products used in Vector control and is engineered for prolonged periods of UV exposure. Additionally, the formulation tank is supplied standard with a 2 inch threaded cap and a 3-piece Pad locking mechanism for security concerns (pad lock not included). The “latch/prop/tool” serves several purposes, it acts as a **latch** to secure the cover over the insecticide pump, as a **prop** to hold the cover in the open position, and a tool to aid opening the formulation tank threaded cap.

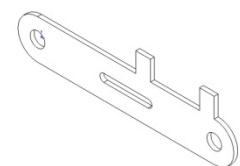

Latch/Prop/tool

Note: Use only products specifically intended for ULV use as outlined on the product label.

INSECTICIDE PUMP

The standard pump supplied with this sprayer is an FMI (Fluid Metering Inc.) metering pump coupled to a 12-volt DC electric motor. This piston pump is driven by an 8-volt regulator as recommended by the pump manufacture. Because of the metering properties of this insecticide pump, regulating the power to the motor ensures a steady and repeatable flow each and every time regardless of possible fluctuations in input power. This standard pump configuration is considered a “Fixed” flow method as the amount of product pumped through the system and to the atomization nozzle is fixed at a user’s predetermined rate. Variable flow models of this FMI pump and other types of variable flow pump control systems are available.

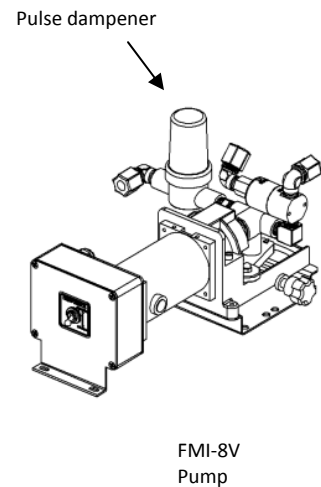

PULSE DAMPENER

The FMI insecticide metering pump is a “piston” type pump that has 2 variables associated with controlling flow. The RPM of the DC motor is a variable that is controlled through the 8V regulator; the second variable being the angle of the piston itself. Generally speaking, the greater the piston angle (away from the centerline of the pump), the greater the pulsations that are generated with each and every pump revolution. For optimal atomization results, a smooth even linear flow is desired through the nozzle.

FLUSH TANK AND VALVE

Some formulations are best not left inside the pump and valves for prolonged period of non-use due to corrosion and formulation thickening. To clean the insecticide pump and valve, a flushing solution is pumped through both the 3-way valve and pump and atomized through the nozzle to clear away residuals remaining inside. A 1.5 Quart flush solution tank is located next to the insecticide pump; ensure it is filled with a flushing solution before use if flushing is desired. Not all formulations require flushing.

To flush out the spray system after use, with the engine running, assert the toggle switch (lower right) on the operator’s control pendant to the FLUSH position illuminating the yellow LED next to it. Turn the spray switch to the ON position. Flushing solution will begin atomization through the sprayer. Turn the spray switch to the OFF position after the operator is satisfied that sufficient time has elapsed to clean out the fluid system. Turn the Flush switch back to NORMAL.

ATOMIZATION NOZZLE

The atomization nozzle is designed to efficiently and effectively atomize various oil and water based formulations to micron diameter droplet sizes as outlined on the specific formulation label. Keep the nozzle clean and free from dings and dents to maintain perfect concentric alignment of the main body and the nozzle cone. Formulation is fed through the rear of the nozzle by way of a stainless steel tube exiting from the closest 45° elbow to the nozzle. The nozzle swivels 360° horizontally and 180° vertically to position the nozzle at the desired attitude. The most common nozzle position is pointed directly toward the back with an upward 45° degree attitude.

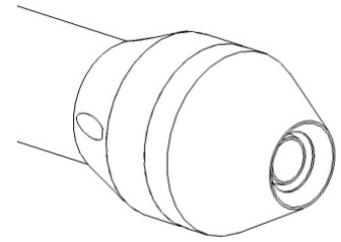

INSTALLATION

COLD FOG GENERATOR (ULV SPRAYER) CONTENTS

The ULV sprayer is packaged in a corrugated box that protects the machine from damage in shipping and storage and is strapped to a wooden pallet for easy lifting by a pallet jack or fork lift. The shipping pallet is not meant nor recommended to be used for permanent or semi-permanent installation on vehicle or trailer. The shipping box and pallet may be retained for storage if desired.

Guardian 95 ES ULV sprayer consisting of two major sections, the drive train section and the flow control or “wet” section. To control this sprayer remotely, an operator’s pendant with cable is supplied (standard) or an optional variable flow control operators interface is also available.

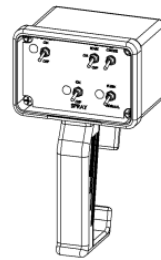

Control Pendant

The Drive Train section includes:

- a. Engine and std. fuel tank if applicable
- b. Positive displacement blower and intake filter
- c. Blower discharge piping, atomizing nozzle with chemical injection plumbing, pressure gauge and tubing
- d. Drive belt, pulley’s and guards
- e. Battery box and cables (Battery not included)

Flow Control “Wet” section includes:

- a. Chemical tank, draw tube, locking cap, and associated chemical tubing and fittings
- b. Extended Fuel tank, fuel valve and hose if applicable (optional)
- c. Fluid filter, pulsation dampener, flush tank, 3-way valve and pressure switch
- d. Fluid pump (FMI standard) with control interface

FACTORY FLUID LEVELS

When you receive your Guardian ULV sprayer, the fluid levels will be as follows:

Engine Oil	Full
Blower Oil	Full
Fuel Tank	Empty
Formulation Tank	Empty

Each machine is fully tested functionally and appropriate fluid levels are services beforehand. Additionally, each machine’s atomization nozzle is fully tested, the results documented and maintained by the manufacturer.

VEHICLE INSTALLATION

1. Remove the packaging box by cutting and disposing of the strapping material. With a fork lift or hoist, lift the machine and remove the pallet and wooden runners from the sprayer.
2. Place the sprayer onto the vehicle or trailer with the engine and blower facing the rear of the vehicle. The Guardian 95 ES is designed to fit between the wheel wells of most small trucks. If placing onto a pickup truck, ensure the tail gate will close if desired. Make sure the engine exhaust has ample area in which to discharge and heat from the exhaust can dissipate without causing damage to surrounding surfaces. The exhaust pipe “turn out” swivels 360° to quickly aid best positioning.

Note: ADAPCO is not responsible for mounting and securing the Guardian ULV sprayers onto a vehicle; it is the responsibility of the owner or end user to do so. ADAPCO will only make recommendations on how to accomplish the placement and securing of this unit.

3. Secure the ULV sprayer to the vehicle or trailer. If electing to bolt the sprayer to the vehicle or trailer, the recommended hardware is: (SS = Stainless Steel)
 - a. 3/8-16 bolts Grade 8 (18-8 SS or better) length as required 4 ea.
 - b. 3/8 flat washer (18-8 SS or better) top side 4 ea.
 - c. 3/8 over sized flat washer (18-8 SS or better) bottom side 4 ea.
 - d. 3/8 lock nut or lock washer with nut (18-8 SS or better) 4 ea.

- Loosen the two T-handle knobs on the Nozzle tube and adjust the nozzle vertically and horizontally to the desired position then retighten the T-handle knobs to secure.

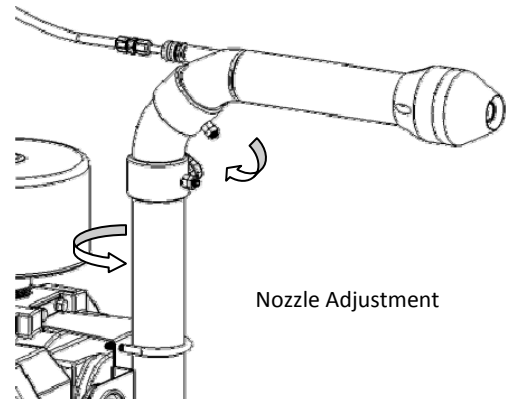

- Place a Lawn and Garden type battery 7.5”L x 5”W x 7.25”H (example- Interstate SP-30) with at least 230 cold cranking amps into the battery box and attach the cables. Attach the RED cable to the batteries (+) positive post first, then connect the BLACK cable to the batteries (-) negative post last to reduce the potential for arcing.

- The Remote pendant is intended to be located inside the vehicle at the driver/operator’s reach. To extend the remote pendant’s cable from the front of the vehicle to the back often requires an access hole to make this possible. Many vehicles have just such existing holes or access panels on the underside often in the rear floor panel or lower rear bulkhead of a pick-up truck. If your vehicle does not have such an access hole, you will need to drill or punch a 1 ¼ to 1 ½ inch hole for clearance of the pendant cable connector. If a more temporary installation is desired, you may pass the pendant cable through a window opening.

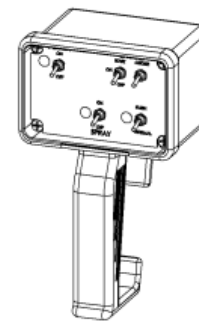

- Route the pendant cable through the access hole and either through or over the bed rail if applicable, back to the ULV sprayer. Lift the sprayer’s cover over the formulation pump and prop open with the latch/tool.

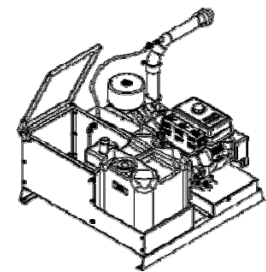

- On the right front corner you will find a bulkhead cable grommet which the pendant cable connector is routed through. Connect the pendant cable to the corresponding connector inside the pump housing and lower and latch the cover.

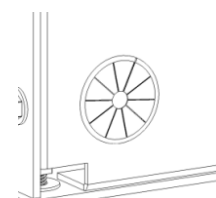

Cable Grommet
Rt. Front corner

9. Fill the fuel tank with unleaded gasoline of not less than 87 octane. **ALWAYS** take precautions when filling the machine with fuel. **NEVER** fuel the machine while running and **ALWAYS** wait for a hot machine to cool before fueling.



ENGINE STARTING







The Guardian 95 ES has a 9.5 hp Kawasaki engine that has a key switch connected electrically to the starter motor on the engine. There are three ways to start this engine:

- a. At the engine with the key
- b. Using the Remote Pendant
- c. Pull starting

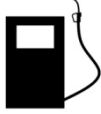
In all cases it is import to note that the KEY must ALWAYS be in the ON position in order for the engine to start.

When the engine is cold, the manual choke will be required to start the engine. After the engine is warm, the choke should not be required in most cases.

Engine Symbols

 <p>Fuel On</p>	 <p>Fuel Off</p>	 <p>Choke off</p>	 <p>Choke On</p>		
<p>Fuel selected allowing gravity feed of gasoline to the carburetor</p>	<p>Fuel valve to this position turns the fuel to the carburetor off</p>	<p>In this position, the choke is in the normal "RUN" mode</p>	<p>To aid in cold starting the engine. Return to choke OFF position when started</p>	<p>Run fast mode increasing the engine RPM the farther toward this position</p>	<p>Idle or slow mode decreasing engine RPM the farther toward this position</p>

The oil level sensor will stop the engine and flash the LED beside this symbol when the oil level gets too low. The engine won't restart without adding oil. If the engine is tilted too much during operation, it may suddenly stop even though the oil level is not too low.



Key Start

1. First turn the fuel valve to the ON position by aligning the fuel valve knob with this symbol. 
2. Next, turn the key clockwise to the first detent. This position breaks the ignition electrical path to Ground and allows spark at the spark plug when the engine is turning over.
3. On the remote pendant, turn the Power toggle switch to the on position illuminating the red Power LED on the pendant. Next, flip the Engine start toggle switch to the ON (center) position.
4. Then, turn the key on the engine farther clockwise past the spring loaded position engaging the starter while at the same time engaging the manual choke to the "choke on" position until the engine fires. Once the engine has fired and is running, return the choke lever back to the normal "choke off" position.
5. To stop the engine, turn the key back to the off position.

Recoil Start (pull start)

1. Follow the first 3 steps of the KEY START procedure.
2. Firmly grasp the recoil starter rope handle and with strength pull to full extent. Repeat as required and also apply the manual choke as required to start engine.
3. To stop the engine, turn the key back to the off position.

Remote Pendant Start

1. First turn the fuel valve to the ON position by aligning the engine fuel valve selector with this symbol. 
2. Next, turn the key on the engine clockwise to the first detent “RUN” position. This position breaks the ignition electrical path to Ground and allows spark at the spark plug when the engine is turning over, **leave the key in this position unless needing to stop the engine directly at the machine.**
3. On the remote pendant, turn the Power toggle switch to the ON position illuminating the red Power LED on the pendant. Next, flip the Engine start toggle switch to the ON (middle) position.
4. Next, on the remote pendant press the Engine Start toggle switch farther to the spring loaded START position engaging the electrical starter until the engine fires.

Note: The Choke toggle switch on the remote pendant is inoperative on the 95 ES model.

MAINTENANCE

CHECKING ENGINE CRANKCASE OIL LEVEL

1. The engine oil level should be checked after every 8 hours of operation or daily as instructed in the Engine Operator’s Manual furnished with this machine.
2. Level the machine and engine to ensure accurate inspection and to prevent overfilling.
3. Unscrew the oil gauge, wipe its dipstick dry, and insert it into the filler hole but DO NOT SCREW IT IN.
4. The oil level should be between the “H” and “L” marks on the dipstick.
5. Add engine oil as required to maintain a level between the H and L marks, refer to the Engine Owner’s Manual for viscosities according to geographic temperature ranges.

CHANGING ENGINE CRANKCASE OIL

1. After the first 8 hours of operation, change the engine crankcase oil. Thereafter, change the engine crankcase oil every 50 hours of operation or annually whichever occurs first.
2. With engine off and preferably warm but not hot enough to cause a burn, slide a shallow oil catch pan directly under the oil drain plug. Loosen and remove the oil gauge dipstick and set aside. Loosen the oil drain plug and remove allowing the crankcase oil to drain into the pan below until the flow of oil has stopped. Warm oil will drain more freely and completely.
3. Replace the engine oil drain plug securely but do not over tighten.
4. Fill the engine crankcase with fresh engine oil; refer to the Engine Owner's Manual for proper viscosities according to geographic temperature ranges.
5. Check and verify the engine oil level to be between the "H" and "L" marks on the dipstick as described in the Engine Owner's manual and the preceding section.

ENGINE AIR CLEANER

For any air cleaner, the operating environment dictates how often the air cleaner should be serviced. Refer to the Engine Owner's Manual for Instructions.

CAUTION- To prevent excessive engine wear, do not run the engine with the air filter removed.

WARNING- DO NOT use gasoline or low flash point solvents to clean the air filter.

BLOWER LUBRICATION

DRIVE END LUBRICATION- drive end bearings are grease lubricated at the factory with Lithium Complex based grease. For re-lubrication, use Gardner Denver AEON PD Grease, Part number 28H283. AEON PD grease is a high temperature, high performance grease that is formulated with anti-wear additives to provide superior service under severe operating conditions. It contains rust inhibitors which provide excellent protection against corrosion.

If you choose not to use AEON PD grease, select compatible grease with NLGI Grade 2 EP, contain rust inhibitors, and be suitable of blower discharge temperatures up to 350°F (177°C).

GEAR END LUBRICATION- The timing gear teeth are lubricated by being partially submerged in oil. The gear teeth serve as oil slingers for gear end bearings. The factory recommended lubricant is AEON PD Synthetic Lubricant which is formulated especially for positive displacement blowers to provide maximum protection at any temperature. AEON PD Synthetic lubricant will last a minimum of 4X longer than a premium mineral oil, depending on actual operating conditions. This Gardner Denver 3MP blower oil capacity is approximately 2/3 PT.

A clear sight gauge or window is located on the blower indicating lubrication oil level. Ensure the oil level is maintained in the middle of the sight gage.

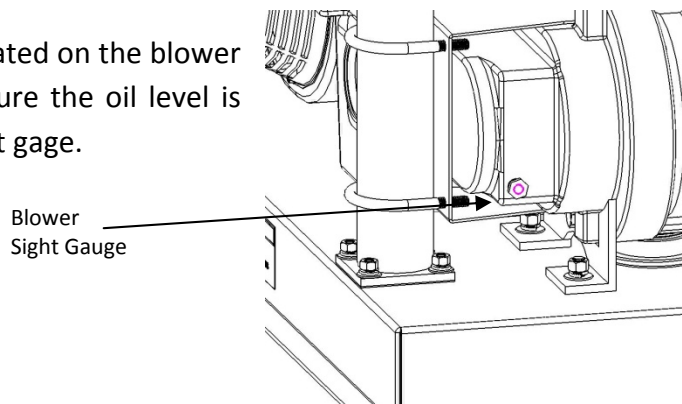

CLEANING THE MACHINE

- Keeping this ULV machine clean is paramount in maintaining a well running and efficient ULV sprayer.
- Washing this machine after each use is highly recommended.
- Use warm water and general duty cleaners.
Pressure washing is not recommended!
- DO NOT spray electrical components directly.



BELT TENSION

Correct belt tension and alignment is essential for proper operation and longevity of this ULV sprayer. When adjusting the belt tension, ensure the alignment is maintained when the fasteners are loosened and retightened after adjustment. Use a straight edge across the face of the blower pulley and align the engine's pulley face with it before securing the engine mounting bolts.

An over-tightened drive belt can cause excessive pulley wear, shorten the belt's life and place too much strain on bearing surfaces of the devices being driven. Conversely, a belt too loose allows slippage and under performance of the machine. The best method for setting the proper tension is the "Deflection" method. A good rule of thumb is $1/64$ " of deflection for every inch between the pulley centers. In the case of the Guardian 95 ES, the center to center dimension is approximately 21" thereby calculating a deflection of $.328$ " or between $5/16$ " to $3/8$ " deflection.

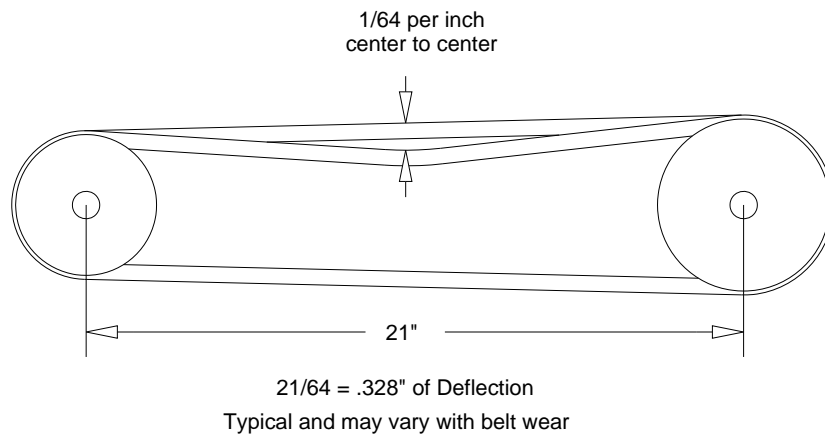

In the final analysis, **the correct belt tension** is just enough tension to keep the belt from slipping under normal load conditions.

LUBRICATION AND MAINTENANCE

BREAK-IN		(AFTER FIRST 8 HOURS)			
EVERY 8 HOURS (DAILY)		EVERY 25 HOURS		EVERY 50 HOURS	
EVERY 100 HOURS		EVERY 200 HOURS		EVERY 500 HOURS OR ANNUALLY	
				PROCEDURE	COMMENTS
X				Check all hardware for tightness	
X				Check drive belt for proper alignment	
X				Change engine oil (break-in)	See Engine Owner's Manual
X				Check engine oil level	See Engine Owner's Manual
X				Check blower oil level	
X				check or clean engine air intake screen	See Engine Owner's Manual
X				Check belt tension	
X				Wash and clean ULV sprayer	See cleaning machine- this manual
X				Check all hardware for tightness	
X				Clean air filter foam element	See Engine Owner's Manual
	X			Clean fuel filter element	See Engine Owner's Manual
	X			Check and clean atomization nozzle	
	X			Check and verify formulation calibration	
	X			Change engine oil	See Engine Owner's Manual
	X			Clean air cleaner paper element	
	X			Change engine oil	See Engine Owner's Manual
	X			Clean and regap spark plug	See Engine Owner's Manual
	X			Clean formulation filter	
	X			Check battery	
	X			Check and clean blower air intake element	
	X			Grease Blower bearings (grease zerts)	
		X		N/A this model	
			X	Clean and rinse formulation tank	
			X	Replace air cleaner paper element	
			X	*Clean combustion chamber	
			X	*Clean and lap valve seating surface	
			X	*Check and adjust valve clearance	

6000 HOURS **Change blower oil See blower lubrication in this manual
 1500 HOURS Change blower oil If using mineral oil

* Have an authorized Kawasaki engine dealer perform these services

**If using AEON PD Synthetic Lubricant

CALIBRATION

There are two types of calibrations that are commonly performed to ensure proper parameters are being maintained for both formulation FLOW and atomization DROPLET spectrums. Perform these calibrations in the order outlined in this manual.

FLOW CALIBRATION

Calibrating the insecticide pump is essential to applying the proper dosage of chemical or insecticide calculated for the average or fixed intended speed of the vehicle installed on. For instance, if the average intended speed of the vehicle is 10 mph, then the insecticide flow should match the calculated value to maintain the correct active ingredient per acre as noted plainly on the product label. Complete the following steps in order to calibrate the insecticide pump:

1. Determine what the desired flow rate per minute is before going further.
2. Loosen the nylon fitting at the nozzle elbow and redirect the chemical tube back into the formulation tank or a clean catch container (1 gallon minimum).
3. Place the toggle switch on the insecticide pump to the UP position to allow the pump to operate without blower air pressure.
4. On the Control Pendant, turn Power ON illuminating the red power LED. Turn Spray ON illuminating the green LED. The pump will begin to run at a steady RPM and flow established from the formulation tank through the filter and fluid system and pumped back into the tank.
5. Once a steady flow is established, loosen the knurled thumb nuts at both sides of the pump and adjust the pump pointing device in a positive or negative direction to increase or decrease flow. The 0 (center) position is the least flow position, and the further away from the 0 center position increases flow. Tighten the knurled nuts after each adjustment.
6. Using a graduated cylinder with adequate volume, place the flowing chemical tube into the graduated cylinder for 1 minute exactly then quickly remove the chemical line and redirect it back to the formulation tank. Turn the spray switch OFF on the control pendant.
7. Read the volume captured in the graduated cylinder and compare it to the desired rate per minute established in step 1. Repeat steps 5 and 6 as necessary until reaching the desired flow rate.

8. Verify flow rate is acceptable by turning spray ON and filling up the graduated cylinder to the highest graduated mark, record the volume then turn spray OFF. Reconnect the chemical line back to the mating nylon fitting at the nozzle elbow and disconnect the chemical line from the formulation draw tube and place that chemical line into the full graduated cylinder. On the insecticide pump, place the toggle switch to the “down” position.
9. Start the sprayer and turn the spray switch to the ON position for 1 minute exactly then turn the spray OFF and shut off the engine. Note: Atomization will occur during this minute; this must be performed in an appropriate uncongested area.
10. Determine the amount of product atomized for one minute by subtracting the amount remaining in the graduated cylinder from the amount established in step 8. This amount should match the desired flow rate from step 1.
11. Adjust the pump pointer to fine tune the rate, repeat steps 8-10 if necessary. Once the pump calibration is set, tighten the knurled thumb nuts securely to prevent the pump from moving.

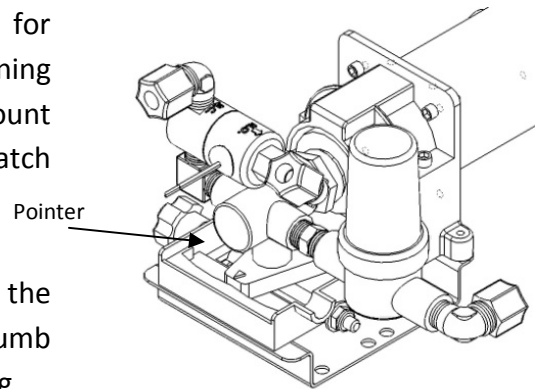

The FMI pumps piston always rotates in the same direction; however, either port can be used as the input depending on which side of the “0” (center) position is desired.

Example- **FIG. A** represents the piston adjusted to the left of center therefore; the direction of flow is to the left as visualized from above. Conversely, **FIG. B** indicates adjustment to the right of center and the flow direction is to the right.

-3 2 1 0 1 2 3-

-3 2 1 0 1 2 3-

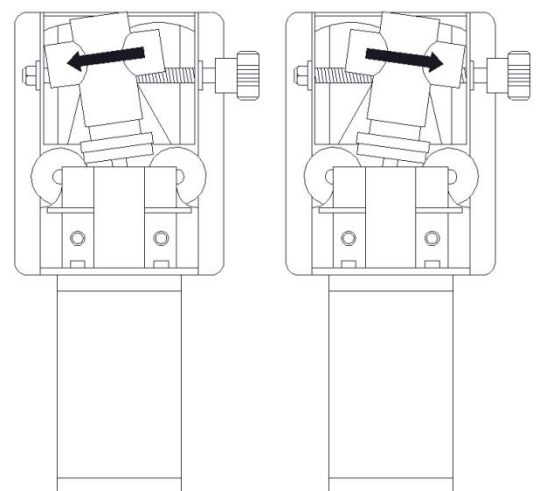

FIG. A

FIG. B

DROPLET SPECTRUM CALIBRATION

Different countries and/or regions of the world may have stringent procedures or regulatory protocols for the atomization of insecticides. Adhere to these restrictions and follow the guidelines set forth on products used through this machine where required.

There are various ways to measure droplet sizes produced from this machine. Refer to the guidelines of the regulatory agency in your area for recommendations and types of acceptable methods.

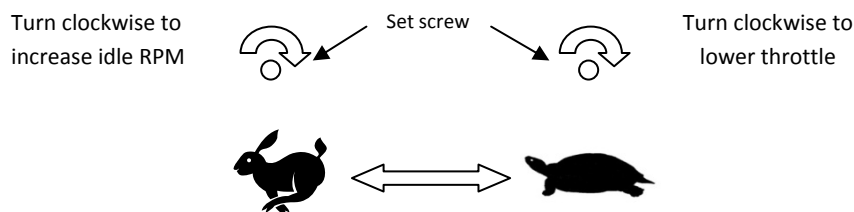

Adjustments on the engines throttle linkage are located on the engines front panel just above the label as shown above. The set screw to the upper right and above the slow speed icon adjusts the maximum RPM so that each time the engine is started, the correct engine RPM can be achieved by moving the throttle mechanism to the full movement and against the stop.

Droplet calibration is accomplished by setting the engine RPM to produce a specific nozzle back pressure as viewed on the air pressure gauge. An increase in engine RPM produces an increase in nozzle back pressure. Use the method for measuring droplet diameters based on the calibrated flow rate of the insecticide pump and adjust the throttle and pressure as required to meet the specific product guidelines.

Note: Different formulations, different viscosities, and different flow rates all require a specific nozzle back pressure to atomize to a desired size.

WIRING DIAGRAM (SPRAYER)

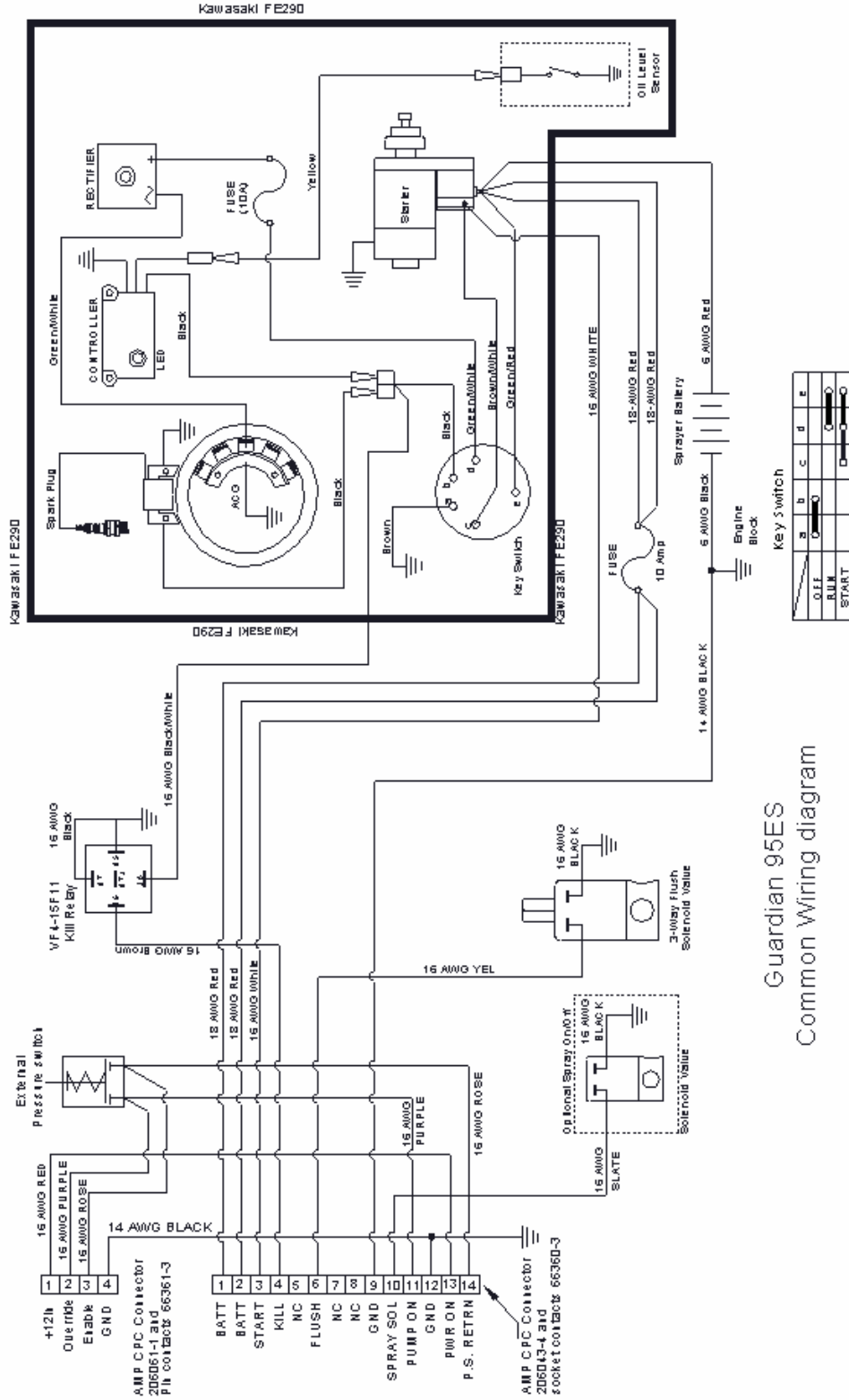

Guardian 95ES
Common Wiring diagram

WIRING DIAGRAM (PENDANT)

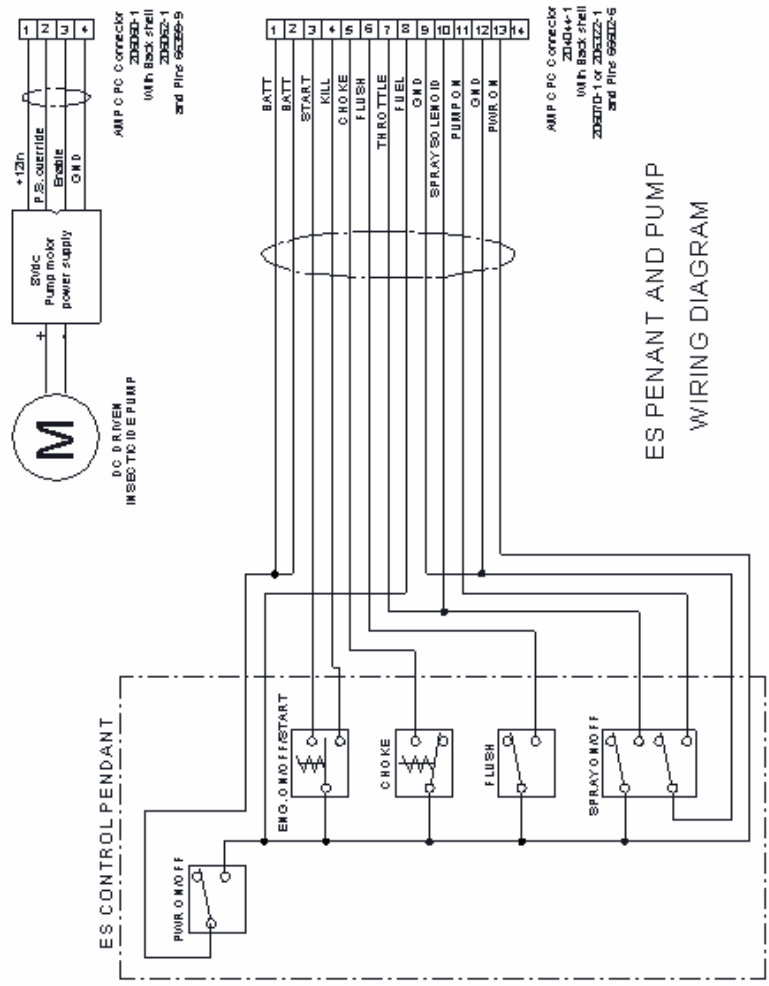

FLOW DIAGRAM

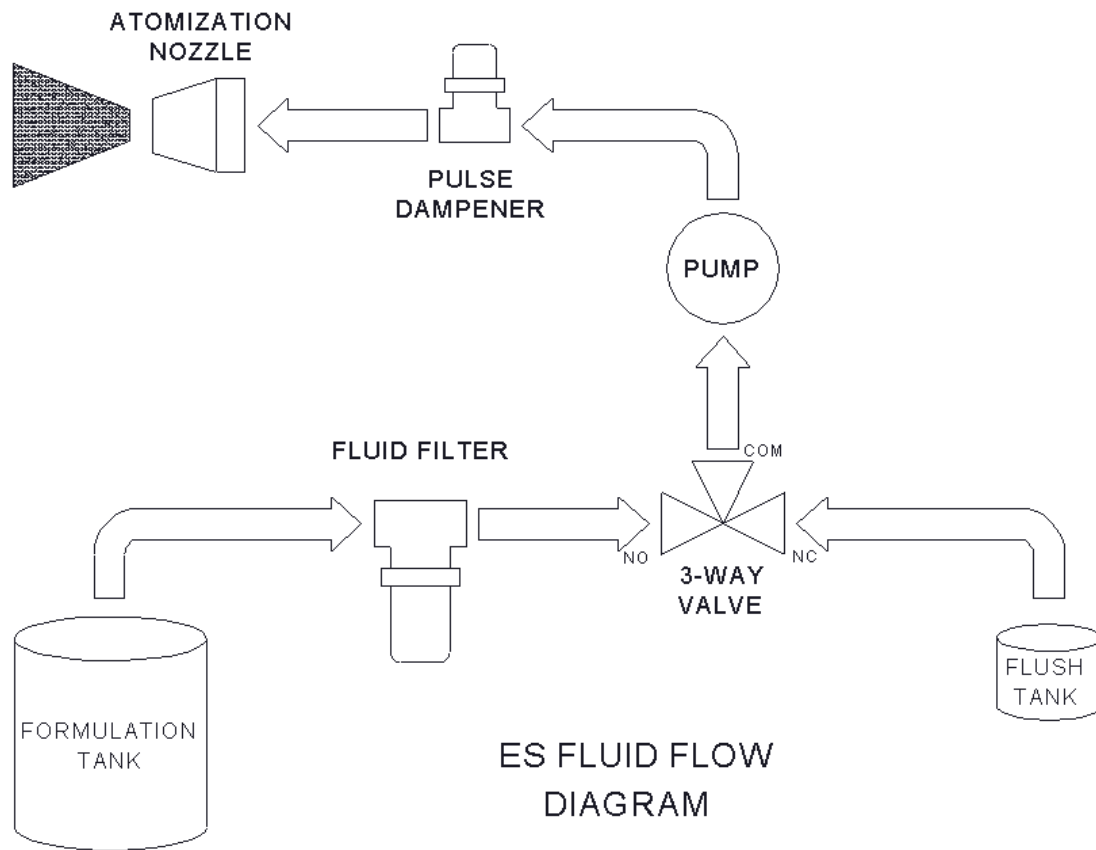

TROUBLESHOOTING

SYMPTOM	PROBABLE CAUSE	REMEDY
1) No power or switch indication on Pendant	Blown fuse Loose battery connection Dead battery Cable not connected	Check and Replace if blown Tighten and/or clean Recharge or replace Reconnect
2) Engine starter motor will not turn over engine	Bad starter solenoid switch Bad starter motor Low or dead battery Loose battery connection Blower locked up	Test and replace if bad Replace Recharge or replace Tighten and/or clean Inspect for free rotation, check lubrication levels
3) Engine will not start from key switch	Engine kill relay asserted Fuel selector valve Empty fuel tank Blocked fuel filter or tube Faulty carburetor	Turn power on on pendant and engine to ON Turn on Fuel selector valve Add fuel Clean or replace Have authorized Kawasaki repair center perform this service
4) Engine will not start in any mode	Fuel selector valve Empty fuel tank Blocked fuel filter or tube Faulty carburetor Over-rich fuel/air mixture Clogged air cleaner Incorrect grade or type of fuel water in fuel Faulty spark plug Key on engine in the OFF position Engine oil level too low	Turn on Fuel selector valve Add fuel Clean or replace Have authorized Kawasaki repair center perform this service discharge excess fuel, clean spark plug Clean Change Gasoline Change Gasoline Replace spark plug Turn key to the ON position Add oil
5) Engine overheats	Clogged air cleaner Recoil starter or cooling path clogged Insufficient engine oil Carbon build up in combustion chamber	clean clean Add or change oil Have authorized Kawasaki repair center perform this service
6) Insecticide pump will not run	Pressure switch contacts open Cable connections loose or disconnected Low battery bad spray switch 8-volt regulator failure	check that pressure switch contact close when engine is on. Check pump and pendant cables connected Check battery voltage, change if low Replace Repair or replace
7) No flow through insecticide pump	Air leak Fluid Filter clogged 3-way solenoid valve clogged Insecticide pump	tank to suction port of pump for air leaks or cracks check and clean, check for air leak disassemble valve and check for cloggs piston and seals
8) No air flow through atomization nozzle	Drive belt broken or excessively loose & slipping Blower internal components damaged Obstruction in nozzle or air tubes Obstruction in Blower lobes	Replace or tighten Phone sprayer manufacture for servcie Check for obstructions Check for obstructions
9) Blower knocking	Unit out of time Worn gears Worn bearings	Retime impellers, consult operator's manual Replace timing gears Replace bearings
10) Excessive blower temperature	Too much oil in gear cas Too low operating speed Dirty air filter Clogged baffle box or muffler	Reduce oil level increase blower speed Clean or replace filter Remove obstruction
11) Lack of blower air volume	Loose slipping drive belt Worn clearances Dirty air filter	Tighten belt Re-establish proper clearances Clean or replace filter
12) Loss of blower oil	Headplate, gear case or drive cover vents plugged Worn seal	Clean vents Replace seals

ILLUSTRATED PARTS BREAKDOWN

GUARDIAN 95 ES DRIVE TRAIN

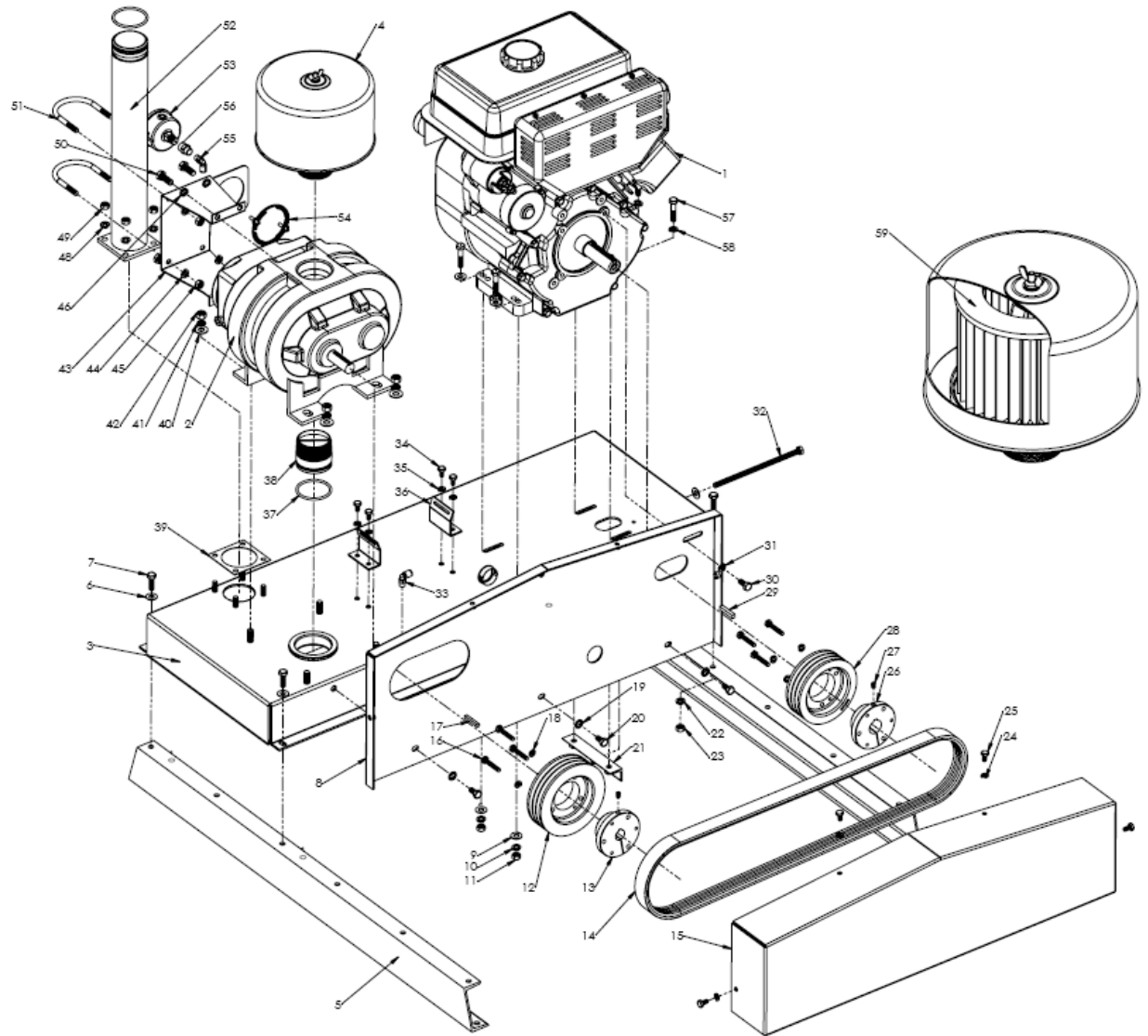

GUARDIAN 95 ES DRIVE TRAIN PARTS LIST

Ref. No.	Part No.	Description	Ref. No.	Part No.	Description
1	1865-510	Engine, 9.5HP Kawasaki FE290D-S21	34		1/4-20 x 1/2" hex bolt
2	1865-514	95ES Positive displacement blower 2"	35		1/4" split lock washer
3	1865-350	95ES baffle box assembly	36	1865-327	ES battery box tie down bracket
4	1865-401	95ES blower air intake filter assembly 2"	37	1865-511	95ES o-ring, EPDM #227,
5	1865-339	ES small blower frame rail	38	1865-348	95ES 2" blower discharge nipple
6		5/16" flat washer	39	1865-380	95ES Stand pipe gasket
7		5/16-18 x 1" hex bolt	40		3/8" Flat washer
8	1865-338	ES small blower belt shroud inside panel	41		3/8 Split lock washer
9		5/16" flat washer	42		3/8-16 hex nut
10		5/16" Split lock washer	43	1865-337	ES small blower standpipe support brkt.
11		5/16-18 hex nut	44		5/16" Split lock washer
12	1865-503	ES Sheave, 5.3 OD, 3V	45		5/16-18 hex nut
13	1865-513	ES Sheave bushing, 3/4" shaft SD type	46		3/8" Split lock washer
14	1865-508	95ES Tripple V-Belt	48		5/16" split lock
15	1865-336	ES small blower belt shroud outside panel	49		5/16-18 Hex nut
16		1/4-20 x 1.5" hex bolt	50		3/8-16 x 1" hex bolt
17		Keyway 3/16" x 1-3/8 lg Steel (blower)	51		5/16-18 x 2" U-bolt
18		1/4" split lock washer	52	1865-355	95ES Nozzle stand pipe
19		5/16" internal tooth lock washer	53	1865-500	Pressure gauge, 0-15 psi, liquid filled
20		5/16-18 x 5/8" hex bolt	54	1865-501	Pressure gauge panel mount bracket
21	1865-343	95ES Engine adjuster bracket	55	1865-504	1/8 NPT x 1/4 tube elbow push-to-lock ftg.
22		5/16" Split lock washer	56	1865-505	Brass reducer coupling 1/4 x 1/8
23		5/16-18 hex nut	57		5/16-18 x 1.5 hex bolt
24		1/4" split lock washer	58		5/16 split lock washer
25		1/4-20 x 1/2" hex bolt	59	1865-402	95ES SS replacement filter element
26	1865-512	ES Sheave bushing, 1" shaft SD type	60	1865-509	Snap grommet 1.250 OD
27		1/4-20 x 3/8 set screw	61		10-32 X 3/8 machine screw
28	1865-503	ES Sheave, 4.75 OD, 3V	62	1865-545	Engine kill relay
29		Keyway 1/4" x 1-3/8 lg Steel (Engine)	63	1865-400	Engine air filter (pleated paper)
30		M8 x 1.25 x 18mm hex bolt	64	1865-401	Engine air pre-filter (foam)
31		5/16" Split lock washer	65	1865-414	Engine spark plug
32		5/16-18 x 7" all thread hex bolt			
33	1865-504	1/8 NPT x 1/4 tube elbow push-to-lock ftg.			

GUARDIAN 95 ES FLUID SECTION

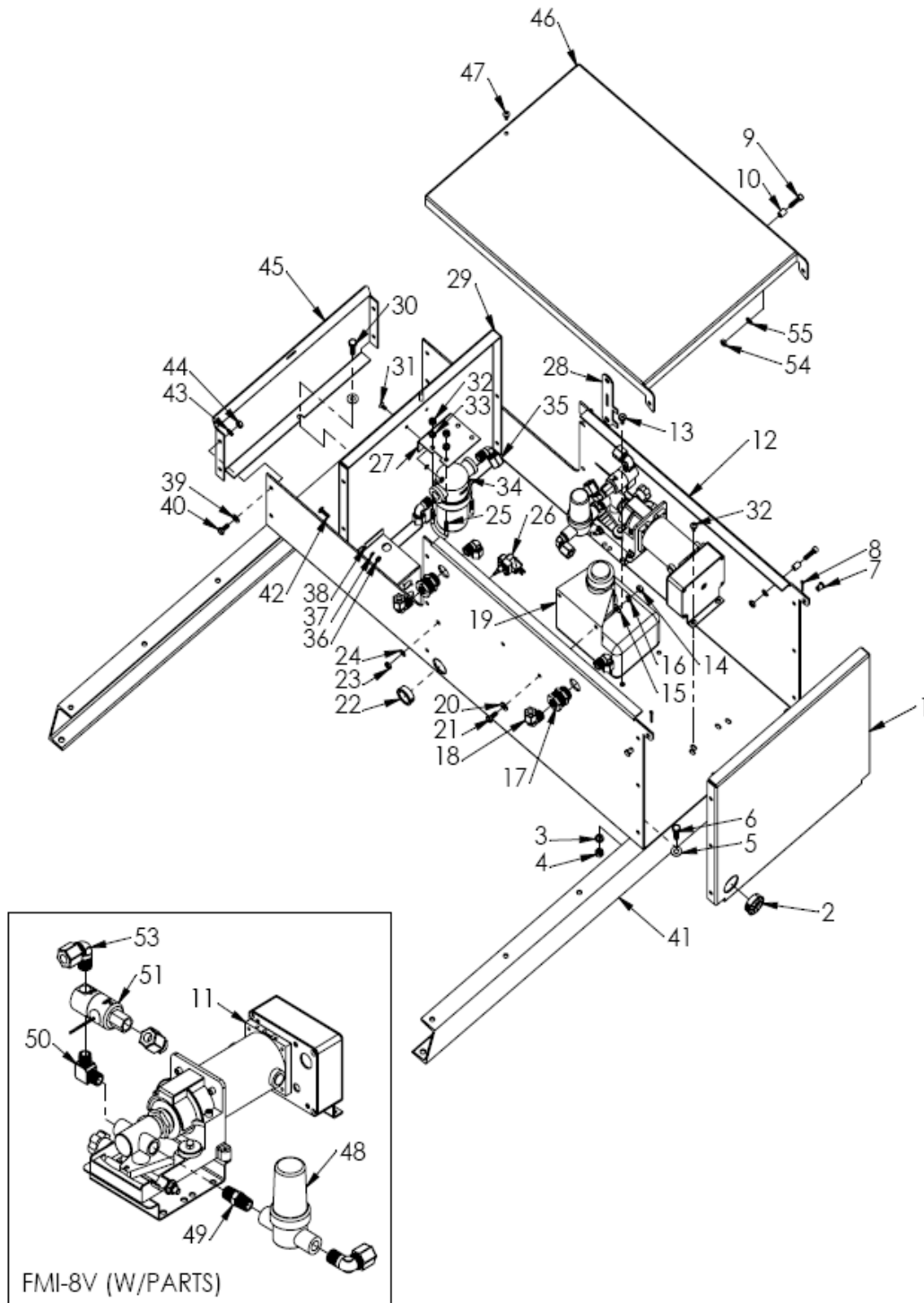

GUARDIAN 95 ES FLUID SECTION PARTS LIST

Ref. No.	Part No.	Description	Ref. No.	Part No.	Description
1	1865-304	ES fuel tank end panel	31		10-32 x 7/16" LG flat head phillips screw
2	1865-506	ES cable entry grommet, 1.375 OD	32		1/4-20 hex nut
3		5/16" split lock washer	33		1/4" split lock washer
4		5/16-18 hex nut	34	1865-397	ES filter bowl assembly (complete)
5		5/16" flat washer	35	1865-515	Elbow, 3/8NPT x 3/8 hose, Nylon
6		5/16-18 x 1" hex bolt	36		10-32 lock nut
7		ES 5/16 x 1/2" clevis pin, stainless steel	37		#10 split lock washer
8		ES cotter pin 1/8" x 3/4" LG.	38	1865-305	ES connector bracket
9		1/4-20 x 1" cap screw	39		1/4" flat washer
10		Spacer, Aluminum 3/8OD x 1/2" LG.	40		1/4-20 x 5/8" hex bolt
11	FMI-8V	ES fixed flow QB pump with switching reg.	41	1865-339	ES small blower frame rail
12	1865-301	ES "wet side" tray	42		10-32 x 3/4" LG pan head screw
13		1/4-20 x 5/8" Pan head screw	43		1/4" split lock washer
14		1/4-20 hex nut	44		1/4-20 hex nut
15		1/4" flat washer	45	1865-302	ES "wet side" chemical end panel
16		1/4" split lock washer	46	1865-333	95ES pump lock box cover
17	1865-507	ES polypro. Bulkhead fitting, 3/8 NPT	47		10-32 x 3/8" Pan head screw
18	1865-515	Elbow, 3/8NPT x 3/8 hose, Nylon	48	1865-517	Pulse dampener, 1/4 NPTF
19	1865-066	Flush tank assembly	49		1/4" NPT brass hex nipple
20		1/4" flat washer	50		1/4" NPT brass elbow
21		1/4-20 x 5/8" hex bolt	51	1865-518	Valve 3-way solenoid, 12 VDC
22	1865-509	Snap grommet 1.250 OD	52		1/4-20 x 5/8" Pan head screw
23		1/4-20 short hex nut (pressure switch)	53	1865-519	Elbow, 1/4NPT x 3/8 hose, Nylon
24		1/4" external tooth lock washer	54		1/4-20 hex nut
25		1/4-20 x 1.25" U-bolt	55		1/4" split lock washer
26	1865-516	Pressure switch, 2 psi barbed			
27	1865-326	ES chemical filter bowl bracket			
28	1865-306	ES Prop/lock/tool			
29	1865-303	ES fuel/chemical tank bulkhead			
30		5/16-18 x 1.25" LG hex bolt			

GUARDIAN 95ES NOZZLE & FORMULATION TANK

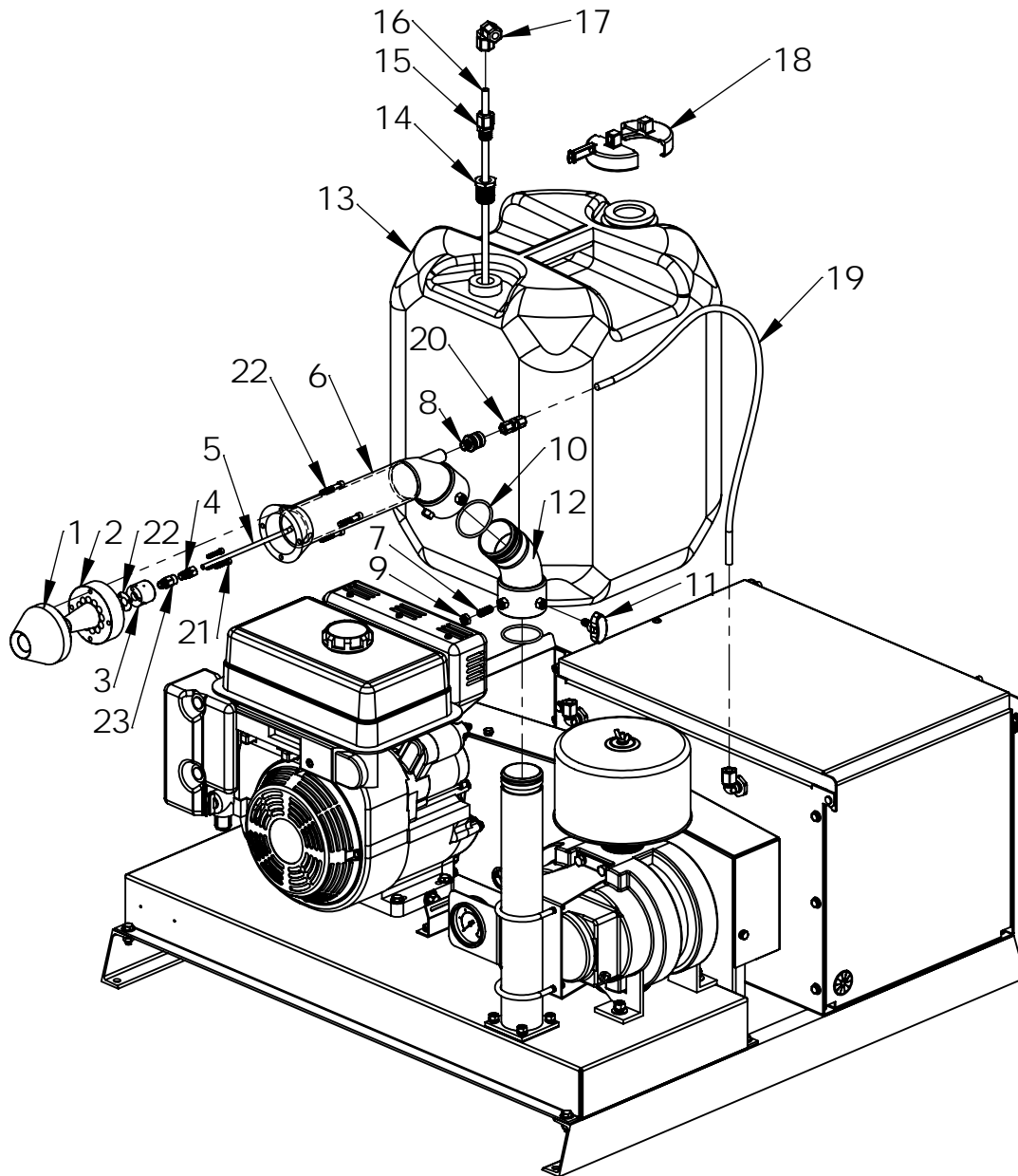

Ref. No.	Part No.	Description	Ref. No.	Part No.	Description
1	1865-359	VAAT nozzle concentric cone	12	1865-362	Formulation tank, 15 gallon HDPE
2	1865-358	VAAT nozzle vector inducer	14	1865-523	Reducer bushing 3/4 x 3/8 Nylon
3	1865-357	VAAT nozzle pre-stage injection port	15	1865-320	SS suction/draw tube, 3/8 OD
4	1865-520	Brass fitting, 1/4NPT x 1/4 tube compression	16	1865-524	Fitting 3/8 x 3/8 straight pass through Nylon
5	1865-356	SS tube, chemical input, 1/4"	17	1865-525	Fitting, elbow 3/8T x 3/8T Nylon lock
6	1865-364	95ES long swivel elbow weldment, 2"	18	1865-526	Lock, 3-piece drum cap
7		3/8-16 x 1" SS pilot point set screw	19		Tubing, 3/8 polyethylene LDPE(15 ft. sections)
8	1865-521	Fitting, 1/4NPT x 1/4 tube liquid tight comp.	20	1865-531	Reducing union, Nylon 3/8 x 1/4
9		3/8-16 hex nut (jamb)	21		10-24x1" socket head cap screw
10	1865-511	95ES o-ring, EPDM #227,	22	1865-404	95ES nozzle gasket
11	1865-522	T-handle knob, 3/8-16 x 3/4 glass/polypro.	23	1865-577	1/8" NPT brass check valve
12	1865-361	95ES 45 degree swivel elbow weldment			

GUARDIAN 95ES EFO (Extended Fuel Option)

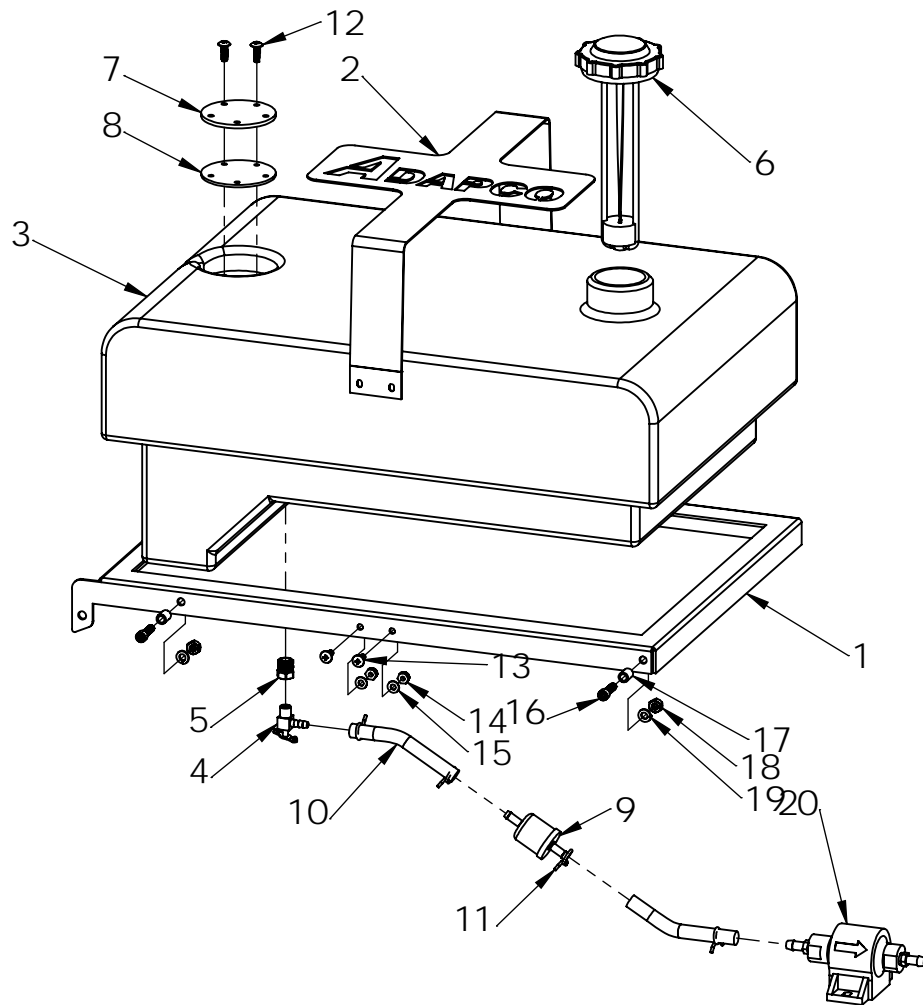

Ref. No.	Part No.	Description	Ref. No.	Part No.	Description
1	1865-335	ES fuel tank steel cradle	11	1865-530	Clamp, fuel hose 1/4"
2	1865-334	ES fuel tank hold down bracket	12		10-24 x 5/8" LG Pan head screw 18-8 SS
3	1865-038	Fuel tank, 8.3 Gallon, Red CLPE	13		10-32 x 1/2" LG truss head screw
4	1865-527	Valve, petcock fuel, 1/8 NPT	14		10-32 nylon lock nut
5	1865-528	Reducer bushing, brass 1/4 x 1/8 NPT	15		#10 flat washer
6	1865-363	Fuel tank cap with float gauge	16		1/4-20 x 1" SS cap screw
7	1865-328	ES fuel tank sensor port cover plate	17		Spacer, Aluminum 3/8OD x 1/2" LG.
8	1865-332	ES fuel tank sensor port cover gasket	18		1/4-20 hex nut
9	1865-529	Fuel filter, inline	19		1/4" split lock washer
10		Fuel hose, 1/4" (36" sections)	20	1865-403	Fuel pump, 12-volt auxillary

NOTES:



GUARDIAN ULV LIMITED WARRANTY

Any part of the commercial Guardian Cold Fog Generator, referred to from this point forward as “ULV sprayer” manufactured by ADAPCO, Inc. and found in the reasonable judgment of ADAPCO, to be defective in materials or workmanship, will be repaired or replaced by ADAPCO or an Authorized Guardian ULV Service Dealer without charge for parts and labor during the periods specified below. This warranty is limited to the original purchaser and is not transferable. Proof of purchase may be required by ADAPCO or by the dealer to substantiate any warranty claims. All warranty work must be performed by ADAPCO or an authorized Guardian ULV Service dealer with the exception of the engine which may be warranty serviced by an authorized Kawasaki engine dealer with prior consent of ADAPCO.

This warranty is limited to the following specified periods from the date of the original end user purchase for defects for materials or workmanship:

- Engines and electric starters are covered by the engine manufactures warranty period subject to following proper operating parameters and maintenance schedules.
- Blower or compressor is covered by the manufactures warranty period subject to following proper operating parameters and maintenance schedules.
- Batteries if supplied are covered for 90 days. Batteries are not normally supplied with this machine.
- Frame and structural components including chassis, belt shroud, covers, enclosures and nozzle piping are covered for 2 years (parts and labor).
- All other components or aspects of this ULV sprayer are conditionally covered for 1 year (parts and labor)

The Guardian ULV sprayer, including any defective part must be returned to ADAPCO or an authorized Guardian ULV Service Dealer within the warranty period. The expense of delivering the ULV sprayer to the service center for warranty work and the expense of returning it to the owner after repair will be paid for by the owner. ADAPCO’s responsibility is limited to making the required repairs and no claim of breach of warranty shall be cause for cancellation or rescission of the contract of sale of any Guardian ULV machine.

The warranty does not cover any ULV sprayer that has been subject to misuse, neglect, negligence, or accident, or that has been operated in any way contrary to the operating instructions as specified in the Operator’s Manual. The warranty does not apply to any damage to the ULV sprayer that is the result of improper maintenance or to any ULV sprayer or parts that have not been assembled or installed as specified in the Operator’s manual or outlined in the Illustrated Parts Breakdown. The warranty does not cover any ULV sprayer that has been altered or modified, changing performance or durability. In addition, the warranty does not extend to repairs made necessary by normal wear, or by the use of parts or accessories which, in the reasonable judgment of ADAPCO, are either incompatible with the Guardian ULV machine or adversely affect its operation, performance or durability.

ADAPCO reserves the right to change or improve the design of any ULV sprayer without assuming any obligation to modify any machine previously manufactured. All other implied warranties are limited in duration to the one (1) year warranty. ADAPCO’s obligation under this warranty is strictly and exclusively limited to the repair or replacement of defective parts and ADAPCO does not assume or authorize anyone to assume for them any other obligation.

ADAPCO assumes no responsibility for incidental, consequential or other damages including, but not limited to expense for gasoline, expense of delivering the ULV sprayer to ADAPCO or an authorized service dealer and expense of returning it to the owner, mechanic’s travel time, telephone charges, travel, loss or damage to personal property, loss of revenue, loss of use of the sprayer, loss of time or inconvenience.

Conditionally- refers to the use on this Guardian ULV sprayer of known and widely used insecticide formulations specified on the product label acceptable for ULV applications or specifically design for ULV use with the exception of insecticide formulation with NALED as the active ingredient. This Guardian ULV machine will not be warranted for any period if the active ingredient NALED is used for any purpose.



Limited Warranty cont.

Guardian Model: 95 ES / 95 ES EFO (circle one)

Serial Number: _____ Record the serial number of your machine here

Date of Delivery: _____ Record the date the unit was received